

Calibration systems for the ANTARES neutrino telescope

J. E. McMillan on behalf of the ANTARES collaboration

Department of Physics and Astronomy, University of Sheffield, Hounsfield Road, Sheffield, S3 7RH, Great Britain.

Abstract. The ANTARES collaboration aims to deploy a 0.1km^2 neutrino telescope in the Mediterranean sea by 2004. Neutrinos will be detected through the muons produced in their interaction with the surrounding matter. The muon trajectory can in turn be reconstructed from the arrival time at the detector photomultipliers of the Cherenkov photons produced by the muons. In order to provide the best possible angular resolution for astronomy a number of calibration techniques will be employed. These include acoustic systems, LED pulsers within the photomultiplier optical modules, brighter omnidirectional LED beacons and a laser beacon. These systems, developed within the ANTARES collaboration, are reviewed and their capabilities described.

1 Introduction

The ANTARES collaboration (Antares, 2001) aims to deploy a 0.1km^2 neutrino telescope in the Mediterranean sea by 2004. The telescope will consist of an array of flexible detector strings moored on the seabed, each string having a total of 90 Optical Modules (Antares, 1999). These optical modules are glass pressure spheres containing photomultipliers (Amram, 2001) which are held three to a storey on an optical module frame as shown in figure 1. Certain of the strings have additional instrumentation to measure environmental parameters, while a dedicated string, known as the “Instrumentation Line” is built with specific instruments to provide more precise measurements and monitoring. Much experience has been gained from a prototype string known as the “demonstrator” which was deployed for eight months starting November 1999.

Neutrinos will be detected in the ANTARES telescope via the muons produced in their interaction with the surrounding matter. The muon trajectory can in turn be reconstructed from the arrival time at the detector photomultipliers of the

Cherenkov photons produced by the muons. This reconstruction of muon tracks is based on precise measurements (~ 1 ns) of the arrival times of the Cherenkov photons at the optical modules. This reconstruction requires knowledge of the positions of the optical modules relative to each other, or more practically with respect to fixed reference points such as the detector string anchors. The precision of this spatial positioning should be better than the uncertainty of the Cherenkov light detection (1ns is equivalent to 22cm of light path in water). It is intended to measure the relative position of each optical module to an accuracy of 10–20cm using acoustic measurements and tiltmeter-compasses.

Relative time calibration of the optical modules is obtained from measurements of the arrival time of short intense light pulses produced by Optical Beacons and a Laser Beacon. These light pulses can also be used to monitor the light attenuation in water as well as for the optical module efficiency calibration. Furthermore, the Laser Beacon located at the bottom of the Instrumentation Line, provides sub-nanosecond light pulses illuminating more than half of the detector. These pulses can be used to monitor the light scattering in sea water and test the reconstruction of a fixed point source.

In addition, the detector calibration can be improved by the knowledge of oceanographic quantities, such as the sound velocity, the water flow velocity and direction, the temperature and salinity of the sea water surrounding the detector. The ANTARES Instrumentation Line carries specific additional instrumentation needed to record and monitor these quantities.

2 Detector relative positioning

The relative positioning of the detector is obtained from two independent systems. Firstly, a High Frequency Long Base Line (HFLBL) acoustic system gives the 3D position of receiving hydrophones attached along the detector lines. Secondly, a set of tiltmeter-compass sensors gives the local tilt angles of each optical module storey with respect to the hor-

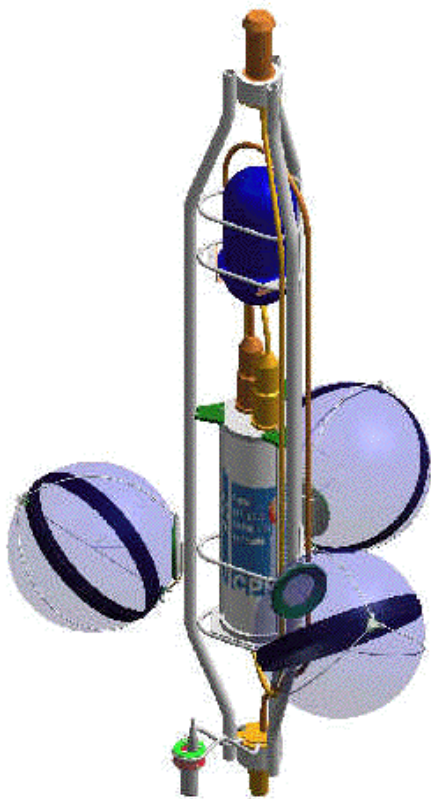

Fig. 1. Frame carrying three optical modules and an optical beacon

horizontal plane (pitch and roll), as well as its orientation with respect to the terrestrial magnetic field. The exact shape of each string is reconstructed by performing a global fit based on the information from these sensors. The relative positions of the optical modules are then deduced from this reconstructed line shape and from the geometry of the optical module frame.

Simulations have been performed (Cassol, 1999) to study the performance of the positioning system for various configurations of the detector calibration equipment (number of acoustic sensors and tiltmeters, locations, precision of sensors, missing sensors), as well as for different values of the sea water current or of the detector string twist as a function of the vertical position on the string. This work shows that a spatial positioning of all optical modules with an accuracy ~ 10 cm is attained, even for a sea water current as strong as 15cm/s.

2.1 Acoustic positioning system

The system is an evolution of a prototype acoustic positioning system developed by the Genisea company for the relative positioning of the ANTARES demonstrator string. The technique used is to measure the travel time of 40-60 kHz acoustic pulses between receiving hydrophones placed along the string and emitters fixed at the bottom of each line. The 3D position of each hydrophone is then obtained by trian-

gulation from the travel times between the hydrophone and each fixed emitter. These fixed acoustic beacons must also be able to receive an acoustic signal in order to determine their own spatial position with respect to the other string anchors.

The acoustic positioning system has been designed to incorporate the four existing autonomous transponders built for the positioning of the demonstrator string. These transponders will continue to be used for the detector positioning when it consists of only a few strings, as well as to improve the quality of the acoustic triangulation of the final detector, if necessary.

The acoustic transponders are currently autonomous emitter/receiver beacons powered by batteries and fixed on pyramidal structures anchored to the seabed. The four transponders are installed at the corners of a 300m by 300m square around the detector. The transponders can be recovered by activating an acoustic release which separates the pyramidal structure from its anchor base. Measurements between all transponder pairs allow their relative positions to be determined by triangulation.

The conversion of acoustic signal travel time measurements to precise distances requires an accurate knowledge of the sound velocity within the detector, and some additional instrumentation is added to the system to provide this. In seawater, the sound velocity depends on the temperature, the salinity and the pressure. The standard model used to determine the sound velocity in seawater according to these quantities is that of Chen and Millero (1977)

In order to measure the sound velocity and its variation, the detector is equipped with five sound velocimeters placed at different locations along the detector strings. The sound velocimeter used, a model developed by Genisea, gives a direct measurement of this quantity by measuring the travel time of an acoustic signal on a fixed length of about 20 cm. The measurement is performed with an accuracy of about 5 cm/s after calibration of the device.

Two sound velocimeters are also equipped with additional Conductivity-Temperature-Depth (pressure) probes to provide an independent measurement of the sound velocity, according to the Chen and Millero (1977) model, and also to obtain an estimation of the salinity (determined from the conductivity and temperature measurements) and temperature gradients within the detector.

The performance of the system used on the demonstrator string was found to be much better than originally specified. The precision of individual distance measurements is better than 1cm, while the accuracy on the 3D positions of the hydrophones obtained by triangulation is 1–3cm. A preliminary description of these results can be found in (Benhamou, 2000) and a full report is in preparation.

2.2 Tiltmeter and magnetic compass

Complementary to the acoustic positioning system, tiltmeters and compasses are necessary for the line shape reconstruction as well as for measuring the optical module orientations. The orientation around the vertical of the three optical mod-

ules of a storey is used to determine the geometrical likelihood of the reconstructed muon trajectory. To obtain this information, each optical module frame is equipped with a biaxial tiltmeter giving the pitch and roll angles and a magnetic compass to determine the direction of the terrestrial magnetic field. The system chosen is the TCM2 manufactured by Precision Navigation Inc, which comprises a small electronic board integrating a biaxial tiltmeter and a 3-axis fluxgate magnetometer. The signals from the sensors are digitised by an ADC and delivered on a serial link to the slow control.

3 Relative time calibration

In addition to the relative positioning of the optical modules, the reconstruction of the muon tracks depends on the relative timing of each phototube signal with respect to others. The goal is to achieve a timing calibration with an accuracy of $\sim 0.5\text{ns}$ in order to avoid degradation of the precision of the Cherenkov light arrival measurements ($\sim 1\text{ns}$) given by the photomultiplier.

The relative timing calibration is performed using three independent and complementary systems; the internal clock calibration, the photomultiplier transit time calibration and the detector relative time offset calibration. The internal clock calibration is performed by the clock distribution system by measuring the clock signal transit time between the on-shore Master Clock and each local clock board. The PMT transit time calibration measures the transit times of every optical module by firing the internal LED included in each Optical Module and by measuring the detection time of the photons. The detector relative time offset calibration is obtained by measuring the relative detection times at many optical modules of photons originating from a single point in the detector. An intense light pulse is generated by one of the two complementary types of beacon. Firstly, Optical Beacons fixed to the Optical Module Frames, which illuminate 8-10 storeys of each neighbouring string. Each detector string is equipped with four Optical Beacons. Secondly, a Laser Beacon fixed on the bottom of the Instrumentation Line, illuminating a large part of the bottom half of the detector strings. It offers an important redundancy for the calibration of the Optical Modules located on the first storeys of every string which are less illuminated by the Optical Beacons.

A global fit of the position and time of the beacon flashes can also be performed to give an independent cross-check of the relative positioning and timing calibrations.

3.1 LED pulsers in optical modules

Photomultiplier average transit time will be measured in the laboratory before deployment and subsequently during data taking. To do this each optical module is furnished with a LED pulser (Amram, 2001) giving a few photoelectrons per pulse. The requirement for jitter in the light source trigger is $< 0.5\text{ns}$ with a drift of $< 0.25\text{ns}$ per year.

The chosen light source is a blue LED driven by a pulser circuit based on an original design from (Kapustinsky, 1985), adapted for use with the most recent blue LEDs and modified to reduce electrical interference with adjacent circuits. Using Agilent HLMP-CB15 LEDs, the pulse risetime (10% to 90%) of 2.0ns and a width (FWHM) of between 4.5ns and 6.5ns (depending on pulse amplitude) has been measured using the single photon technique (Bollinger, 1961).

This circuit has the required timing properties, but the light pulse generated has a high intensity: up to 10^8 photons per pulse. Mechanical reduction of the pulse intensity is therefore necessary and this is obtained in two steps. The LED is encapsulated in a black cap with a tiny pinhole drilled on the side of the cap to select a small fraction of the emitted light. The system is then installed on the rear part of the photomultiplier, and the photocathode is illuminated through the thin aluminised layer deposited on the rear part of the bulb, which serves as an additional neutral density filter. This method has two advantages: the absence of a shadowing effect on the photocathode and a simple mechanical implementation.

3.2 Optical beacons

Montecarlo studies (Navas, 2000) have shown that LED pulsers of the type used in the optical modules are sufficient to illuminate neighbouring strings at the few photoelectron level and thus calibrate the timing of the ANTARES telescope to the required accuracy of sub-0.5 ns. For inter-string and inter-storey calibration it is desirable to have pulsed light sources that are not located within the optical modules, and this inspired the concept of separate, dedicated LED based optical beacons, each contained in its own pressure-resistant vessel.

Such optical beacons, based on many LED pulsers simultaneously triggered are intended to be omnidirectional, at least in the horizontal plane. It has been found experimentally that triggering many of these LED pulsers simultaneously results in a light pulse which is not significantly degraded in terms of time characteristics from that produced by a single pulser. By switching the number of LEDs pulsed and by controlling the intensity of the individual pulsers, a factor of approximately 80 in the amount of light produced by the beacon per pulse is attainable. This provides less intense light pulses for timing calibration measurements and more intense light pulses for studies of the optical properties of the surrounding water. There will be a total of four optical beacons on each detector string.

The current design consists of six faces arranged as a hexagonal cylinder, mounted within a cylindrical glass pressure vessel (Nautilus Marine Service). Each face of the beacon has six LEDs, five facing radially outward and the sixth facing upward to illuminate the string above the optical beacon. Each beacon produces between 3×10^7 and 2.9×10^9 photons per pulse depending on the configuration of LEDs selected. The light pulse from the beacon has a rise time (10% to 90%) of 2.0ns and a width (FWHM) of between 4.5ns and 6.5ns depending on amplitude. The individual faces of the

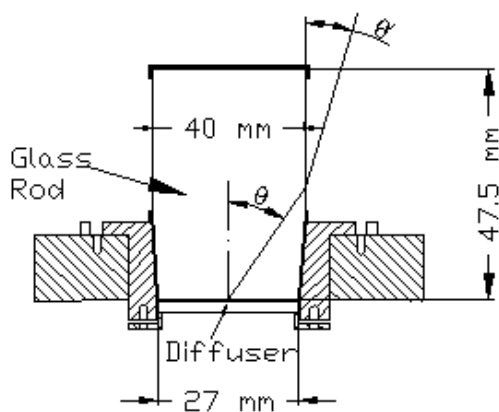

Fig. 2. Laser beacon diffuser

prototype beacon have been experimentally measured to be synchronous to within 200ps.

At present all the LEDs used emit light in the blue at 470nm with a FWHM of 15nm, however, the design is flexible enough to use violet or near-ultraviolet LEDs if there is sufficient interest in water transmission monitoring at these wavelengths and if the individual LED prices permit.

A small fast photomultiplier (Hamamatsu 6780) is included within the beacon to provide a true t_0 of the light flash independent of any trigger electronics. This can also give a measure of the intensity of the light flashes for amplitude calibration purposes. The photomultiplier collects light from the LEDs via an acrylic lightguide in the form of a disc mounted at the top of the beacon. The photomultiplier is mounted centrally on this disc, under a polished conical indentation which directs light onto the photocathode as suggested in Fields (1983)

3.3 Laser beacon

In addition to the LED beacons there will be a much more powerful laser beacon at the base of the instrumentation line. The main component of the beacon is a diode pumped solid state laser, Nanolase model NG-10120-120 which produces intense ($\sim 1\mu\text{J}$), short ($\sim 0.8\text{ns}$ FWHM) light pulses at 532nm which is visible green. The laser is housed in a cylindrical titanium pressure container and is arranged to point upwards. The angular occupancy of the beam is widened by a diffuser which spreads the light out to a cosine distribution. To avoid problems caused by sedimentation, a glass cylinder is bonded to the upper surface of the diffuser, as shown in figure 2, and this forms the window to the pressure container. The light exits through the vertical walls of the cylinder where the sedimentation is negligible. The diameter and length of the cylinder and its refractive index ($n=1.47$) determine the maximum and minimum angles reached. These angles have been selected so as to illuminate the upper and lowermost

storeys of the closest strings.

The laser beacon is triggered from the slow control system and the actual time of emission of the light flash is given by the signal from a built-in fast photodiode which is returned to the data-acquisition system.

4 Conclusion

The systems described are expected to provide sufficient accuracy to reconstruct muon tracks in the ANTARES telescope and to monitor any important changes in the performance of the detectors and the transparency of the seawater.

Acknowledgements. The ANTARES collaboration acknowledges financial support by the Funding agencies, in particular: CEA, CNRS, Commission Européenne (FEDER fund), Département du Var and Région Provence Alps Côte d'Azur, City of La Seyne, France; the Ministerio de Ciencia y Tecnología, Spain (FPA2000-1788); the Instituto Nazionale di Fisica Nucleare, Italy; the Russian Foundation for Basic Research, grant no. 00-15-96584, Russia; the foundation for fundamental research on matter FOM and the national scientific research organization NWO, The Netherlands.

References

- Agilent Technologies, Palo Alto, Ca, USA; see also <http://www.agilent.com>
- Amram, P. et al, The ANTARES optical module, 2001; submitted to Nucl Instrum Meth Phys Res A
- Antares, <http://antares.in2p3.fr/Collaboration>
- Antares, A Deep Sea Telescope for Neutrino Astronomy, Antares Proposal, 1999, preprint astro-ph/9907432; see also <http://antares.in2p3.fr/publications/proposal/proposal99.html>
- Benhamou, Y. et al, Results of line 5, Antares note Antares-Prot/2000-01
- Bollinger, L.M. and Thomas, G.E., Measurement of the time dependence of scintillation intensity by a delayed coincidence method, Rev Sci Instrum, 32(9), p1044-1050, 1961.
- Cassol, F., Antares note Antares-Slow/1999-01
- Chen, C.T. and Millero, F.J., Speed of sound in sea water at high pressures, J Acoust Soc Am, 62(5), p1129-1135, 1977; see also calculation interface at <http://fermi.jhuapl.edu/denscalc.html>
- Fields, T. and Jankowski, D., Simple scheme for light collection from large-area plastic scintillators, Nucl Instrum Meth 215, p131-133, 1983.
- Genisea, 785 Chemin de la Carraire La Cibonne, 83220 Le Pradet, France; see also <http://perso.wanadoo.fr/genisea>
- Kapustinsky, J.S. et al, A fast timing light pulser for scintillation detectors, Nucl Instrum Meth A214, p612-613, 1985.
- Nanolase, 31 Chemin du Vieux Chêne, Zirst 4101, 38941 Meylan, France; see also <http://www.nanolase.com>
- Nautilus Marine Service GmbH, Haferwende 3, D-28357 Bremen, Germany; see also <http://www.nautilus-gmbh.de>
- Navas, S. et al, Antares notes Antares-Cali/1999-001 and Antares-Cali/2000-005
- Precision Navigation, Inc. 5464 Skylane Blvd. Santa Rosa, CA 95403, USA; see also <http://www.pnicorp.com>