

New Experimental set up for UHE Cosmic Ray Detection.

Nayanmoni Saikia^a, Jyoti Prasad Phukan^a, Subhash Chandra Rajbongshi^b, K. Boruah^a, P.K. Boruah^b

(a) Department of Physics, Gauhati University, Guwahati-14, Assam, India.

(b) Department of Instrumentation & USIC, Gauhati University, Guwahati-14, Assam, India.

Presenter: Nayanmoni Saikia (nayan075@yahoo.co.in), ind-saikia-N-abs1-he15-oral

Extensive Air Showers of primary energy $E_p > 10^{17}$ eV are being detected in the mini-array UHE Cosmic Ray Research Laboratory, Department of Physics, Gauhati University, Assam (26°10' N, 91°45' E and altitude 51.8 m) with detectors consisting of eight plastic scintillation counters (50x50x5 cm³ area) viewed by 5" PMT and installed at the roof top of the Physics Building, GU. This experiment is based on Linsley's method of detecting UHE Cosmic Ray Showers by non-conventional low cost array measuring time spread as well as the density of the secondary particle within 2 μ s time window. The experimental setup has been modified recently with the addition of few more components. An important part of the data acquisition system (DAS) i.e. trigger circuit, generates pulses for recording genuine events satisfying the prerequisite selection criteria. In this paper we describe the new design and their performance.

1. Introduction:

Ultra high energy (UHE) Cosmic Ray intensity being very low, conventionally require a large area ground based particle detector array for their detection. But relatively cheap and novel method was proposed by J. Linsley to detect giant extensive air shower (ESA) produced by UHE Cosmic Rays in the atmosphere, by measuring the thickness of the shower front at large core distances by using a roof top mini array. This idea is pursued by us and a mini -array detector consisting of eight plastic scintillation counter was set up in the Physics Department, Gauhati University. This detector is specially designed to measure both the charged particle density and their arrival time at the detector level. The following additional detectors are also added to the original array which has been installed at the roof top of physics building .

1. Scintillation detectors are costly, and therefore low cost Resistive Plate Counters (RPC) designed and developed in the mini-array laboratory are installed and operated with the mini array. (Ref 1&2)

2. For optical pulse detection one Cerenkov detector consisting of a 5" photo-multiplier tube (PMT, Type-9792 KB make EMI) is installed at the roof top of Physics Building at a distance---- from the mini-array hut and is operated in coincidence with this mini-array. (Ref 3&4)

3. For low frequency Radio signal detection associated with the cosmic rays an VLF (3-30 KHz) circular loop antenna of diameter 74.5cm. having 40 turns of Cu wire (SWG 14) with directly couple pre-amplifier is being designed . The pre-amplifier is designed with the low noise, precision operational amplifier op-07 and this system is to be installed at the roof top of the physics building & will be operated in coincidence with the mini-array. (Ref5)

1.1 DATA ACQUISITION SYSTEM:

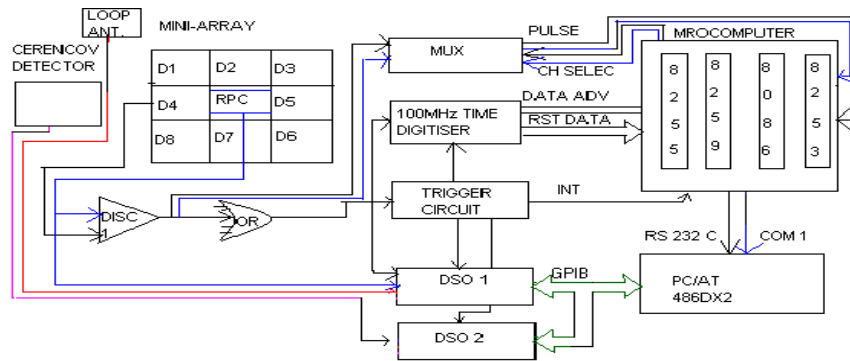

Fig1:Block Diagram of Experimental Set-up.

Block diagram of the experimental set up for data acquisition is shown in fig.1. The event recording is handled by IBM PC(AT 486DX2) with GPIB interface. A microprocessor system is used (8086) to monitor the performance of the particle detector. Two DSO, Tektronix, TDS 520A & Tektronix, TDS 2024 record the particle pulses and associated Cerenkov and Radio pulses. Event trigger is generated by the trigger circuit which is explained below. Whenever trigger occurs recorded data in the oscilloscope is transferred to the computer via GPIB and store in disc. The recorded data is analyzed off line.

1.2 THE TRIGGER CIRCUIT:

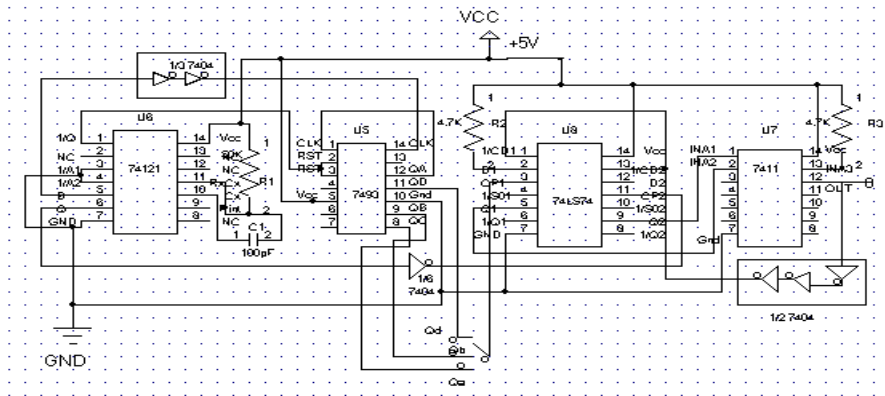

Fig2: Schematic Diagram of Trigger Circuit.

1.3 CIRCUIT DESCRIPTION:

Fig-1 shows the circuit diagram of the trigger circuit. The IC-1(74121) is a monostable multivibrator . IC-1 produces out put pulse which is shaped to 2.5us positive width with the help of external capacitor Cx and resistor Rx that acts as time window.IC-2 (7493) is a four bit binary counter with the four out puts Q_a,Q_b,Q_c and Q_d. Using IC-2 as a 4- bit binary ripple through counter , the out put of 1st flip-flop is connected externally to the in put of the 2nd flip-flop. The complimentary input of IC-1 is connected to the reset in-put R0-1 & R0-2 so that the reset input become low for 2μS. The OR'ed out put is connected to the input pin-14 of IC-2 by two hex inverter (7404) for a 20 ns delay to reset the input pulses. The First clock pulse(Cp1) of IC-3(74LS74, dual D-type edge trigger flip-flop) is taken from any three out put of IC-2 as desired.2nd clock input(CP2) is supplied from out put of IC-1 with through one hex inverter. The D input of IC-3(i.e. pin 1&13) kept high by connecting through resistance to the +5V power supplier. Sd inputs are kept low and Cd inputs are taken from the trigger out put through three hex inverter. The out puts of IC-3(pin-5&11) are fed to the input of IC-4(7411, Triple 3 input and gate). Trigger out put are taken from pin 12 of IC-4.

2. RESULT AND DISCUSSION :

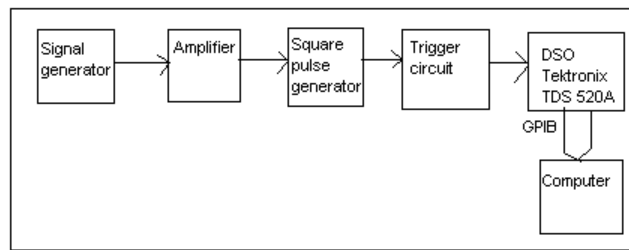

Fig3: Block Diagram of Testing of Trigger Circuit.

Fig3 shows the block diagram of testing of trigger circuit. The trigger circuit produces out –put pulse whenever number of input pulses falls within the time window fixed at 2μS satisfy the pre requisite selection criteria.

Following results are achieved.

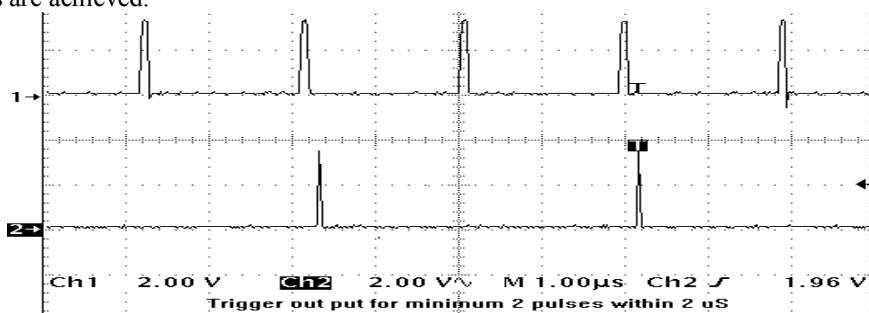

Fig4: Trigger out put for minimum 2 pulses within 2μS.

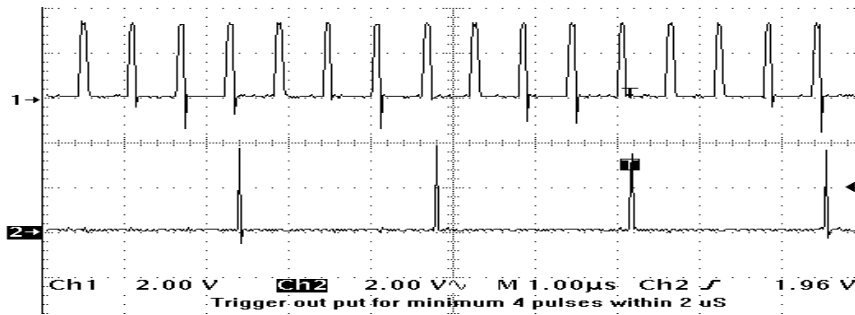

Fig5:Trigger out-put for minimum 4 pulses within 2 μ S .

The following results are noted:

1. The circuit worked successfully with the pulsing unit.
2. Selection could be made according to the desired number(2,4,8) of pulses per stipulated time.
The desired number of pulses can be selected with a slight modification of the circuit.
3. Good noise immunity is achieved due to the use of logic circuit element.

3. Conclusion:

The newly set up mini –array with the four type of detectors will be operated continuously very soon.. The trigger circuit as well as data acquisition system(DAS) has been tested successfully. It is expected that the newly designed trigger circuit will reduce the effect of noise which is a problem with the pulse width trigger circuit, designed earlier. This is expected to reduce the recording of spurious events.

4. ACKNOWLEDGEMENT:

The authors thank the Indian Space Research Organization (ISRO),Bangalore, Department of Space, Govt. of India for financial support in carrying out experimental research.

References:

1. J.P.Phukan, S. C.Rajbongshi, K.Boruah, P.K.Boruah., PANE, Assam, India, Vol. 1, 2000 p. 50-53
2. Subhash Chandra Rajbongshi,Pradip Kr. Boruah,Jyoti P. Phukan,Kalyani Boruah ,in: Proc.28th ICRC, Tsukuba, Japan, H.E. Session !.4-1.5, Vol2/7 p.777-780,2003
3. K.Boruah, P.K.Boruah.,J.P.Phukan in: Proc. 26th ICRC,USA,Vol-2,p.384-386,1999.
- 4.J. P.Phukan,K.Boruah,P.K.Boruah, in: Proc.27th ICRC,Humburg,Germany,Vol.2,p.407-410,2001.
- 5.Renato Romero and Marco Bruno, An Easy VLF Loop,200Hz-20KHz Reception without transformer.