



Upgrade of the MAGIC Telescope with a Multiplexed Fiber-Optic 2 GSamples/s FADC Data Acquisition system

FLORIAN GOEBEL¹, HENDRIK BARTKO¹, EMILIANO CARMONA¹, NICOLA GALANTE¹, TOBIAS JOGLER¹, RAZMIK MIRZOYAN¹, JOSE ANTONIO COARASA², MASAHIRO TESHIMA¹

FOR THE MAGIC COLLABORATION

¹Max-Planck-Institut für Physik, Munich

²UC San Diego / CERN

fgoebel@mppmu.mpg.de

Abstract: In February 2007 the MAGIC Air Cherenkov Telescope for gamma ray astronomy was fully upgraded with a fast 2GSamples/s digitization system. The upgraded readout system uses a novel technique of fiber-optic multiplexing which uses 10-bit 2 GSamples/s FADCs to digitize 16 channels consecutively and optical fibers to delay the analog signals. A distributed data acquisition system using GBit Ethernet and FiberChannel allows to read out the 100 kByte events with a continuous rate of up to 1 kHz.

Introduction

MAGIC [1] is currently the largest single dish Imaging Atmospheric Cherenkov telescope (IACT) for high energy gamma ray astronomy with the lowest energy threshold among existing IACTs. It is installed at the Roque de los Muchachos on the Canary Island La Palma at 2200 m altitude and has been in scientific operation since summer 2004. The 17 m diameter parabolic shaped mirror preserves the time structure of the Cherenkov light signals. The camera is equipped with 576 photo-multiplier tubes (PMTs). The analog signals are transferred via optical fibers to the trigger and flash analog to digital converter (FADC) electronics. Until February 2007 a dual gain 300 MSamples/s 8-bit FADC system [2] has been used. This rather low sampling rate required additional pulses stretching to ensure proper sampling of the signal.

The gamma ray signals are very short and the PMT response time is very fast resulting in 2 ns pulses. A fast readout therefore allows one to minimize the integration time and thus to reduce the influence of the background from the light of the night sky (LONS). In addition a precise measurement of the time structure of the gamma ray signal can help to reduce the background due to hadronic background events [3]. The MAGIC collaboration has thus de-

veloped a new, affordable 2 GSamples/s readout system and fully installed it in February 2007.

The 2GSamples/s Fiber-Optic Multiplexed readout system

Fast flash analog to digital converters (FADCs) are commercially available, but they are prohibitively expensive and power consuming to read out all the pixels of the MAGIC camera. To reduce the costs a 2 GSamples/s read-out system has been developed and tested [4, 5] at the Max-Planck-Institut für Physik in Munich. It uses a novel fiber-optic multiplexing technique. Multiplexing is possible as the signal duration (few ns) and the trigger frequency (typically ~ 1 kHz) result in a very low duty cycle for the digitizer. The Fiber-Optic Multiplexing (MUX) technique results in a cost reduction of about 85% to using one FADC per read-out channel.

The MUX readout system uses a single 2 GSamples/s FADC to digitize 16 read-out channels consecutively. The concept is shown in Figure 1. The analog signals are delayed using optical fibers. Each channel is delayed by additional 40 ns compared to the previous channel. The signals are then electrically multiplexed and finally sent to the

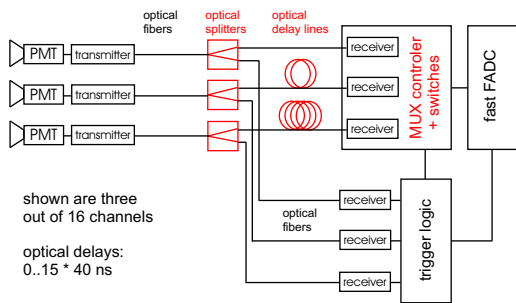

Figure 1: Concept of the fiber-optic multiplexing technique.

FADC. A trigger signal is generated using a fraction of the light, which is branched off by fiber-optic light splitters before the delay fibers.

Optical fibers provide very low pulse dispersion and attenuation and are therefore very well suited for analog signal transmission. Graded index multimode fibers are used to transmit and delay the 850 nm wavelength light generated by the VCSEL diodes in the MAGIC camera. They attenuate the signal by about 2.3 dB for 1 km fiber length. GRIN optical splitters with a mode independent 50/50 ($\pm 3\%$) splitting ratio are used to branch off the trigger signal. The maximum delay of the fibers after the splitters is 1160 ns to account for the 40 ns incremental delay for the 16 channels and 560 ns additional common delay needed to wait for the trigger decision. The optical delay and splitter modules are assembled in 3U standard 19" crates.

On the multiplexer boards the optical signals are converted back to electrical signals using PIN diodes. Fast high bandwidth MOSFET-switches open for 40 ns one channel at a time. Two switches are operated in series to reduce the cross talk to about 0.1%. The switches are controlled by a digital circuit, which is started by a trigger signal. Since the control circuit is clocked at 800 MHz the trigger jitter is 1.25 ns. Finally, the signals are summed in two active summation stages. In Figure 2 the multiplexed signal of 16 pixels digitized by one FADC channel is shown. About 10 ns at the borders of every 40 ns window are affected by the switching process from one channel to the next. These noise peaks have to be removed by the analysis software.

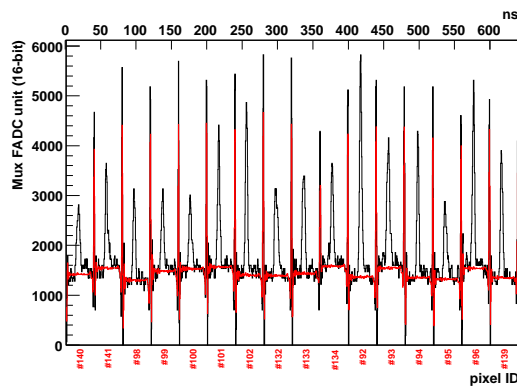

Figure 2: Calibration Event in one FADC Channel with 16 multiplexed PMT signals (black) and corresponding pedestal (red).

The 2GSamples/s FADCs

The multiplexed signals are digitized with DC282 FADC modules produced by the Acqiris company. The DC282 FADCs feature a 10-bit amplitude resolution, a bandwidth of 700 MHz, a sampling speed of 2 GSamples/s and an input voltage range of 1 V. Each DC282 module contains 4 FADC channels and consumes 60 W power. The FADC intrinsic noise corresponds to about 1 FADC count. The DC282 FADC modules map the intrinsic 10-bit FADC data to 16-bit numbers. This mapping compensates for small FADC intrinsic nonlinearities, which are determined during a special calibration procedure.

The digitized data are stored in an on-board 512 kByte RAM per channel. The dead time before the next event can be recorded is about 25 μ s. Two FADC boards are inserted in each of the 5 compact PCI (cPCI) crates. A crate controller PC running Linux reads the data via the 66 MHz 64 bit cPCI bus. The on-board RAM is logically subdivided into 3 segments with capacity for 50 events (2.5 kBytes/event). As soon as 50 events have been written into a segment, new digitized data is stored in the next segment. The previous segment is then read out asynchronously via cPCI. A sustainable readout rate of more 1 kHz with no additional dead time could thus be achieved.

Digital data like trigger bits or the precise time information provided by a GPS clock is recorded

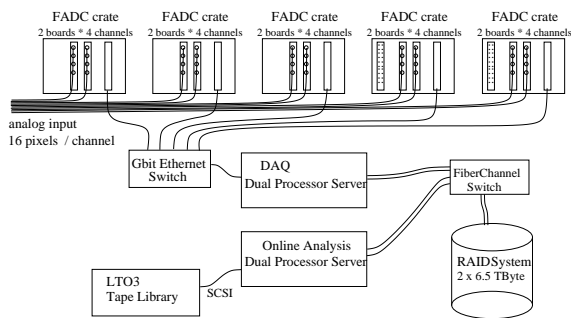

Figure 3: Schematics of MUX FADC data acquisition system.

simultaneously with each event. Four Acromag PMC-DX504 modules installed in two of the cPCI crates are used to read up to 120 LVDS bits with every trigger. This data is then read by the crate controller PC and merged with the FADC data.

The Data Acquisition System

The schematics of the data acquisition is shown in Figure 3. In each of the 5 cPCI crates a data acquisition program records the digitized data and stores it in a 2000 event deep ring buffer. The data is then sent to the central DAQ (MUXDAQ), a powerful Dual-Xeon 2.8 GHz server with 8 GB RAM memory running Linux. The data is transferred over a Gbit Ethernet connection using TCP/IP and a dedicated handshake protocol. A maximum transfer rate of 100 MByte could be achieved corresponding to a sustainable trigger rate of 1 kHz.

The main data acquisition program running on MUXDAQ combines the data of all 5 crates and stores it in a 2000 events deep ring buffer. It then checks the data integrity, performs a quick signal reconstruction for online data quality checks and finally saves the data to disk.

The disk storage system was designed to allow high data acquisition rates and fast simultaneous access to the data for an online data analysis without disturbing the data acquisition using FiberChannel and Global File System (GFS) technology. The storage medium consists of two EUROstor RAID systems with 16 SATA disks, 500 GBytes each. They are configured in RAID5. With one spare disk this amounts to 6.7 TBytes

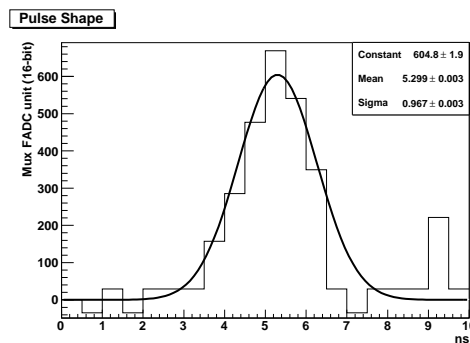

Figure 4: Typical ~ 5 photoelectron signal (histogram) and mean scaled pulse shape of a single photoelectron signal.

storage capacity per RAID system. The RAID systems are connected via two 2 GBit/s FiberChannel lines and a FiberChannel switch to MUXDAQ. A maximum rate of 200 MBytes/s could be achieved writing data to a single RAID system.

In addition to MUXDAQ a second identical server (MUXANA) is connected to the two RAID systems over the FiberChannel switch. In order to access the data simultaneously from both servers, GFS has been installed on the RAID systems. It provides a fast access to the data without interruption on the data taking, even at these high data rates.

The MUXANA server is used for quick data analysis, running the complete MAGIC analysis chain. This allows a quick detection of bright gamma ray sources. In addition a 36 slot LTO3 tape library is connected to MUXANA. During one night rawdata of up to 1 TByte are recorded. This data volume exceeds the bandwidth of the Internet connection to the MAGIC data center. The rawdata is therefore written to LTO3 tapes and shipped to the data center. Using compression 1.1 TByte of MAGIC rawdata can be written to one LTO3 tape. Only the calibrated data which is generated by the quick analysis on MUXANA is transferred via Internet to the data center and is available within 24h after data taking.

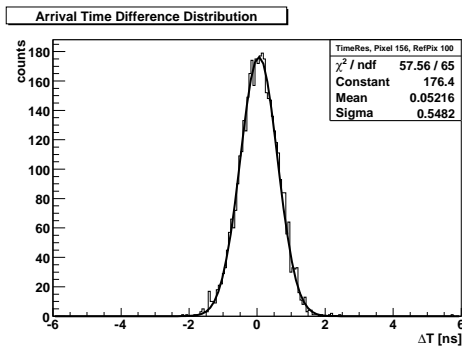

Figure 5: Distribution of the arrival time difference between two camera pixels for calibration events.

System Performance

Since the installation in February 2007 the MUX FADC system has been taking data smoothly. A sustainable data acquisition rate of up to 100 MBytes/s corresponding to a trigger rate of 1 kHz has been achieved.

In Figure 4 a signal corresponding to ~ 5 photoelectrons is shown. A PMT afterpulse signal has been selected to study the response of the whole signal chain to a maximally short input signal. A pulse width of FWHM of 2.3 ns is obtained.

In order to study the time resolution of the whole signal chain, calibration events have been used, which illuminate the camera uniformly with short (few ns) light pulses. In Figure 5 the distribution of the arrival time difference between two camera pixels is shown for calibration events. Two random inner camera pixels have been chosen for which the mean light pulse intensity corresponds to ~ 35 photoelectrons. The arrival time is calculated with the simple algorithm $t = \sum_i t_i q_i / \sum_i q_i$, where i is the FADC slice index, and t_i and q_i are the time and the charge of slice i . The RMS of the distribution is 550 ps corresponding to a time resolution of 390 ps.

The signal gain is currently adjusted such that a single photoelectron produces a mean signal with an amplitude of ~ 2 FADC counts and an area of ~ 9 FADC counts. It thus roughly corresponds to a 3 sigma FADC noise level. Saturation effects of the multiplexer board start to become noticeable at signals corresponding to about 800 photoelectrons,

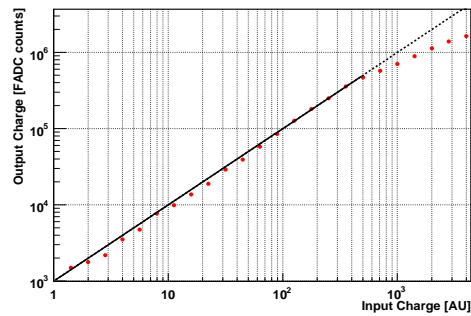

Figure 6: Linearity of the FADC signal as a function of the input pulse area.

thus leading to a linear dynamic range of 800. In Figure 6 the linearity of the reconstructed FADC pulse is shown as a function of the input pulse area. The potential and performance of the fast 2 GSamples/s MUX FADC system to reduce background and to increase the sensitivity of the MAGIC telescope are addressed in[3].

Acknowledgments

We would like to thank the German MPG for special support for the MUX FADC upgrade project and the IAC for excellent working conditions. The support of the German BMBF and MPG, the Italian INFN and the Spanish CICYT, the Swiss ETH and the Polish MNiI is gratefully acknowledged.

References

- [1] E. Lorenz, *New Astron. Rev.* **48** (2004) 339;
- [2] F. Goebel, et al. , “The data acquisition of the MAGIC telescope”, *XXVIIIth International Cosmic Ray Conference (ICRC), Tsukuba, Japan, 31 Jul - 7 Aug 2003*
- [3] D. Tescaro, et al. , these proceedings;
- [4] R. Mirzoyan et al., *IEEE Transactions on Nuclear Science* **49,5** (2002) 2473;
- [5] H. Bartko, et al. , “Tests of a Prototype Multiplexed Fiber-Optic Ultra-fast FADC Data Acquisition System for the MAGIC Telescope”, *Nucl. Instr. and Meth. A* **548** (2005) 464;