

DESIGNED & DIMENSIONED  
IN INCHES[MILLIMETERS]

ZHSI-XX-XX

DO NOT  
SCALE FROM  
THIS PRINT

STACK HEIGHT

- 01: SEE TABLE 1  
(USE ZHSI-P-01-N AND ZHSI-S-01-N)
- 02: SEE TABLE 1  
(USE ZHSI-P-01-N AND ZHSI-S-02-N)
- 03: SEE TABLE 1  
(USE ZHSI-P-01-N AND ZHSI-S-03-N)
- 04: SEE TABLE 1  
(USE ZHSI-P-01-N AND ZHSI-S-04-N)

HEAD SPECIFICATION

- 01: SLOT HEAD

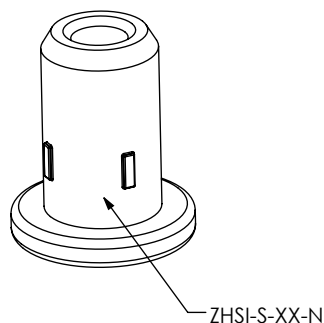
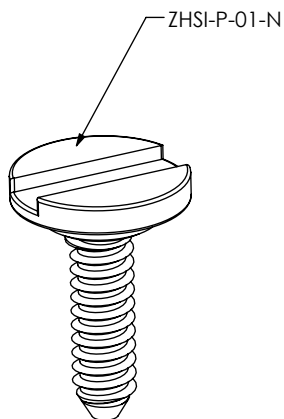

TABLE 1			
PCB 1 THICKNESS	PCB 2 THICKNESS	ZA INTERPOSER HEIGHT	RECOMMENDED STACK HEIGHT
1.57 [0.062]	1.57 [0.062]	1.00 [0.039]	-01
2.36 [0.093]	1.57 [0.062]	1.00 [0.039]	-02
2.36 [0.093]	2.36 [0.093]	1.00 [0.039]	-02
3.18 [0.125]	1.57 [0.062]	1.00 [0.039]	-02
3.18 [0.125]	2.36 [0.093]	1.00 [0.039]	-03
1.57 [0.062]	1.57 [0.062]	0.33 [0.013]	-04

NOTES:

1. NOTE DELETED.
2. NOTE DELETED.
3. PARTS TO BE USED WITH PCB THICKNESSES OF .062" TO .125".
4. COMPONENTS TO BE PACKAGED PER SECTION 8.2 J50 OF CO-RF-WI-3001-M.
5. PLACE HDRL-07 (LABEL) ON BAG. LABEL TO HAVE THE FOLLOWING PRINTED IN ARIAL FONT SIZE 9:  
 LINE 1 - "FOR ASSEMBLY INSTRUCTIONS SEE"  
 LINE 2 - "ZA MATED DOCUMENT"  
 LINE 3 - PART NUMBER "XXXXXX"  
 LINE 4 - SHOP ORDER NUMBER "XXXXXX"  
 LINE 5 - "WARNING, TIGHT TORQUE SPECIFICATION, SEE ZA MATED DOCUMENT"
6. ZHSI HARDWARE IS DESIGNED FOR USE WITH MATING PCB HOLE DIAMETERS OF 2.00MM. SEE ZA MATED DOCUMENT FOR ALL ASSEMBLY INSTRUCTIONS.

UNLESS OTHERWISE SPECIFIED,  
DIMENSIONS ARE IN MILLIMETERS.

TOLERANCES ARE:

- DECIMALS                      ANGLES
- X.X: ±0.3 [.01]                      2°
- X.XX: ±0.13 [.005]
- X.XXX: ±0.051 [.0020]

PROPRIETARY NOTE

THIS DOCUMENT CONTAINS CONFIDENTIAL AND PROPRIETARY INFORMATION AND ALL DESIGN, MANUFACTURING, REPRODUCTION, USE, PATENT RIGHTS AND SALES RIGHTS ARE EXPRESSLY RESERVED BY SAMTEC, INC. THIS DOCUMENT SHALL NOT BE DISCLOSED, IN WHOLE OR PART, TO ANY UNAUTHORIZED PERSON OR ENTITY NOR REPRODUCED, TRANSFERRED OR INCORPORATED IN ANY OTHER PROJECT IN ANY MANNER WITHOUT THE EXPRESS WRITTEN CONSENT OF SAMTEC, INC.



520 PARK EAST BLVD, NEW ALBANY, IN 47150  
 PHONE: 812-944-6733 FAX: 812-948-5047  
 e-Mail: info@SAMTEC.com code 55322

MATERIAL: DO NOT SCALE DRAWING SHEET SCALE: 5:1

BRASS

DESCRIPTION: Z RAY HARDWARE WITH INTEGRATED ALIGNMENT KIT

DWG. NO. ZHSI-XX-XX

BY: SHERRY W 01/16/2015 SHEET 1 OF 1