

MuTRiG

- a Mixed-Signal SiPM Readout ASIC with High
Timing Resolution and High Event Rate Capability

Huangshan Chen
Kirchhoff-Institute for Physics, Heidelberg University

81. Jahrestagung der DPG und DPG-Frühjahrstagung
Münster, 28.03.2017



Mu3e Experiment

Search for $\mu^+ \rightarrow e^+e^+e^-$ at 10^{-16} level

- Forbidden in standard model (BR $< 10^{-52}$)
- Clear sign for new physics

Challenge

Observe 1×10^{17} muon decay within a reasonable measurement time

- Require high event rate, high geometrical acceptance and high efficiency

Suppress background to below a level Of 10^{-16}

- Require good momentum, vertex and timing resolution

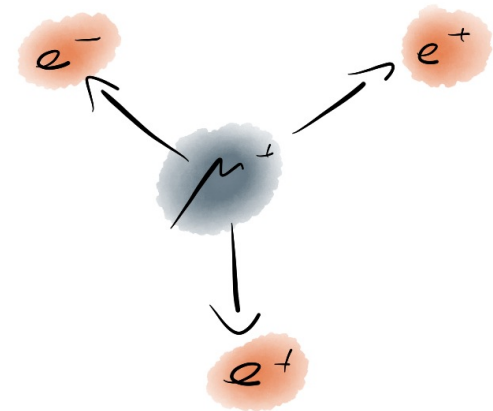

Requirements for Timing Detector

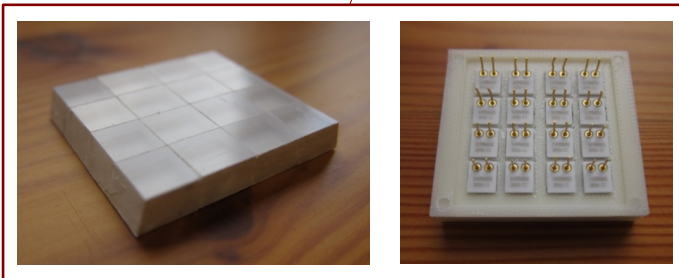
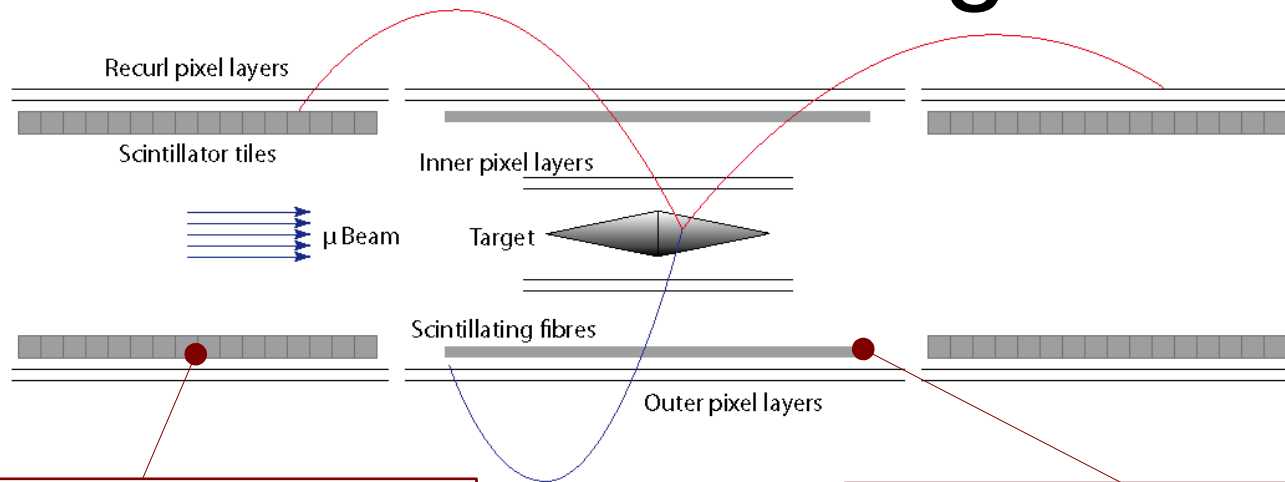

Mu3e tile detectors

6272 SiPM channels

Requirements:

- Timing: **100 ps**
- Event rate : 50 kHz/ch

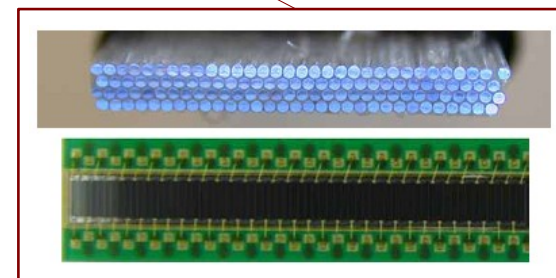

Mu3e fiber detectors

3072 SiPM channels

Requirements:

- Timing: **500 ps**
- Event rate :
700 kHz/ch - 1.3 MHz/ch

STiCv3 Chip

- 64-channel SiPM readout ASIC for Time-of-Flight applications
- Mixed-signal ASIC
 - Fully-differential analog front-end
 - 50 ps time binning TDC
 - On-chip digital circuit for event data processing and transferring to DAQ

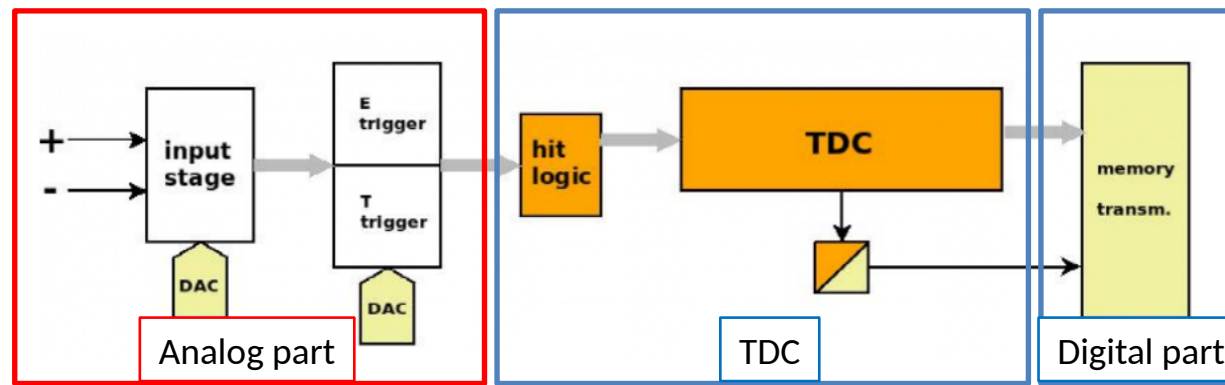
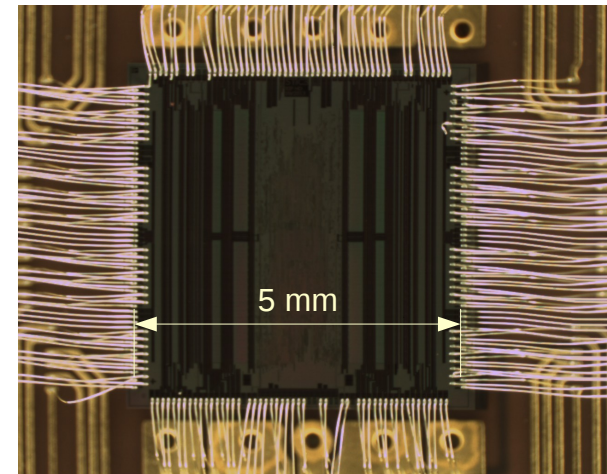

Excellent Timing Performance of STiCv3

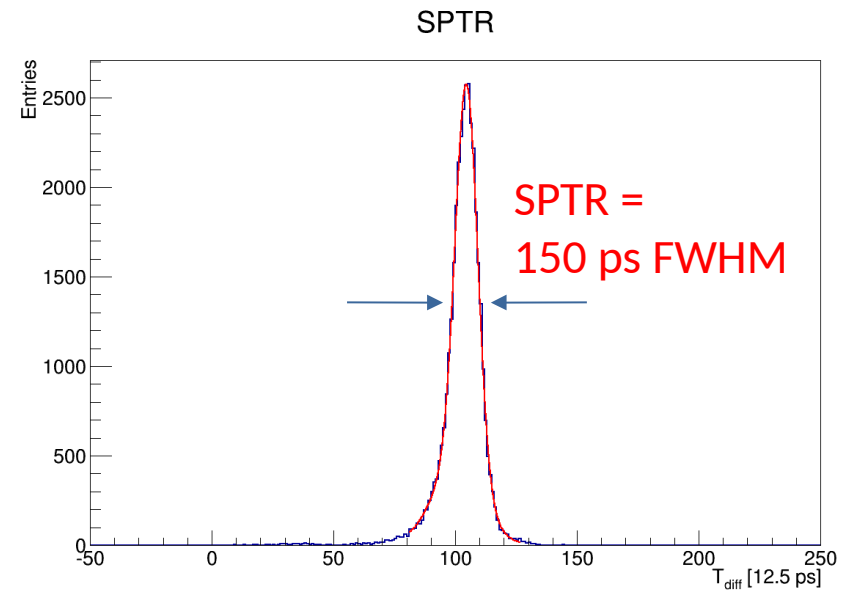
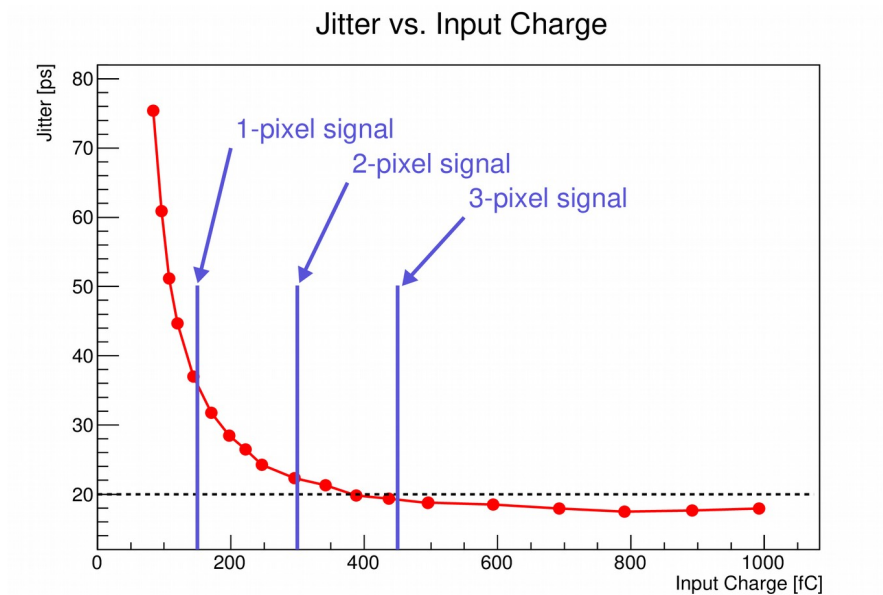

Charge injection measurement

- Analog front-end timing performance
- Time jitter < 20 ps for charge > 450 fC

Single photon timing resolution (SPTR)

- SPTR: 150 ps FWHM

Event Rate Limit on STiCv3

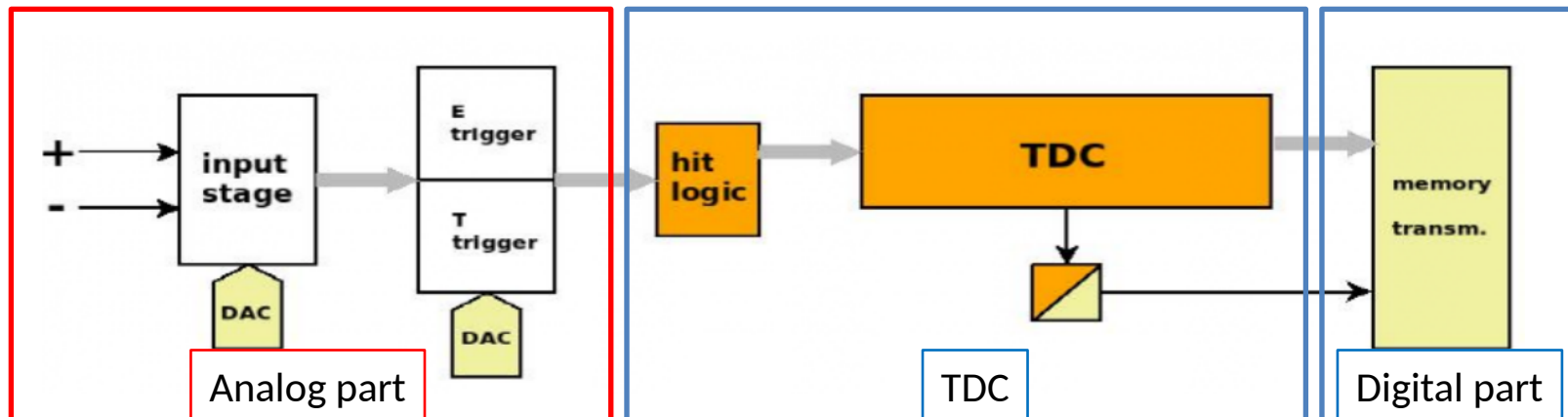

- Dead time depends on the input signal
- Almost no rate limit
- Dead time: 30 - 50 ns
- > 20 MHz/ch
- Serial data link, 160 Mbps per chip
- ~40 kHz/ch

MuTRiG: upgrade of STiCv3

Keep the timing performance

- Fully differential analog front-end
- 50 ps timing binning TDC

Increase the event rate capability

- Much higher serial link data rate:
 - 160 Mbps → 1.28 Gbps
- Switchable output event size:
 - Time + energy, full event (47 bits)
 - Timing + 1 bit energy info (27 bits)
- Less channels:
 - 64 → 32

Upgrade digital logic circuit

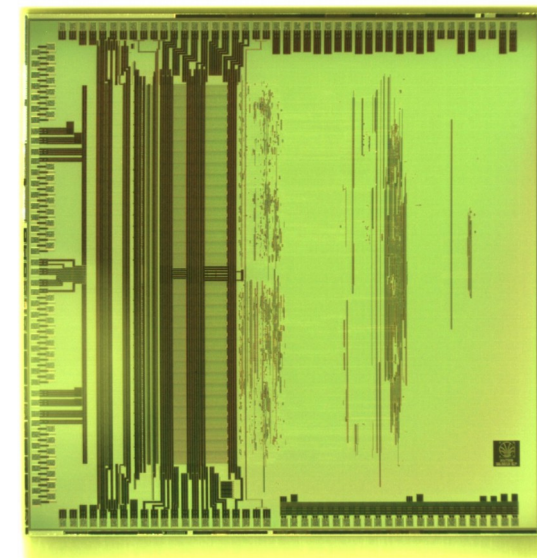
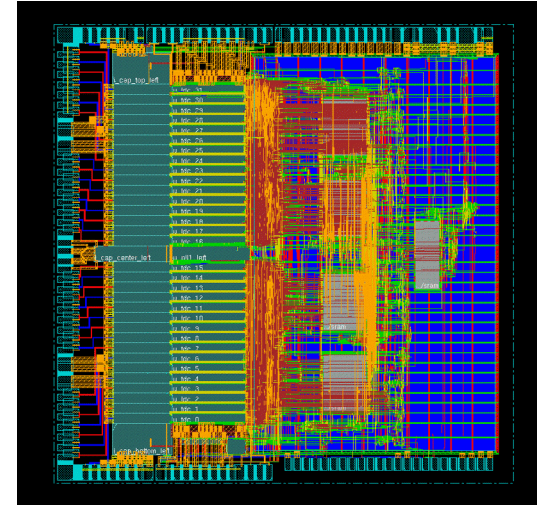

MuTRiG: Block Diagram

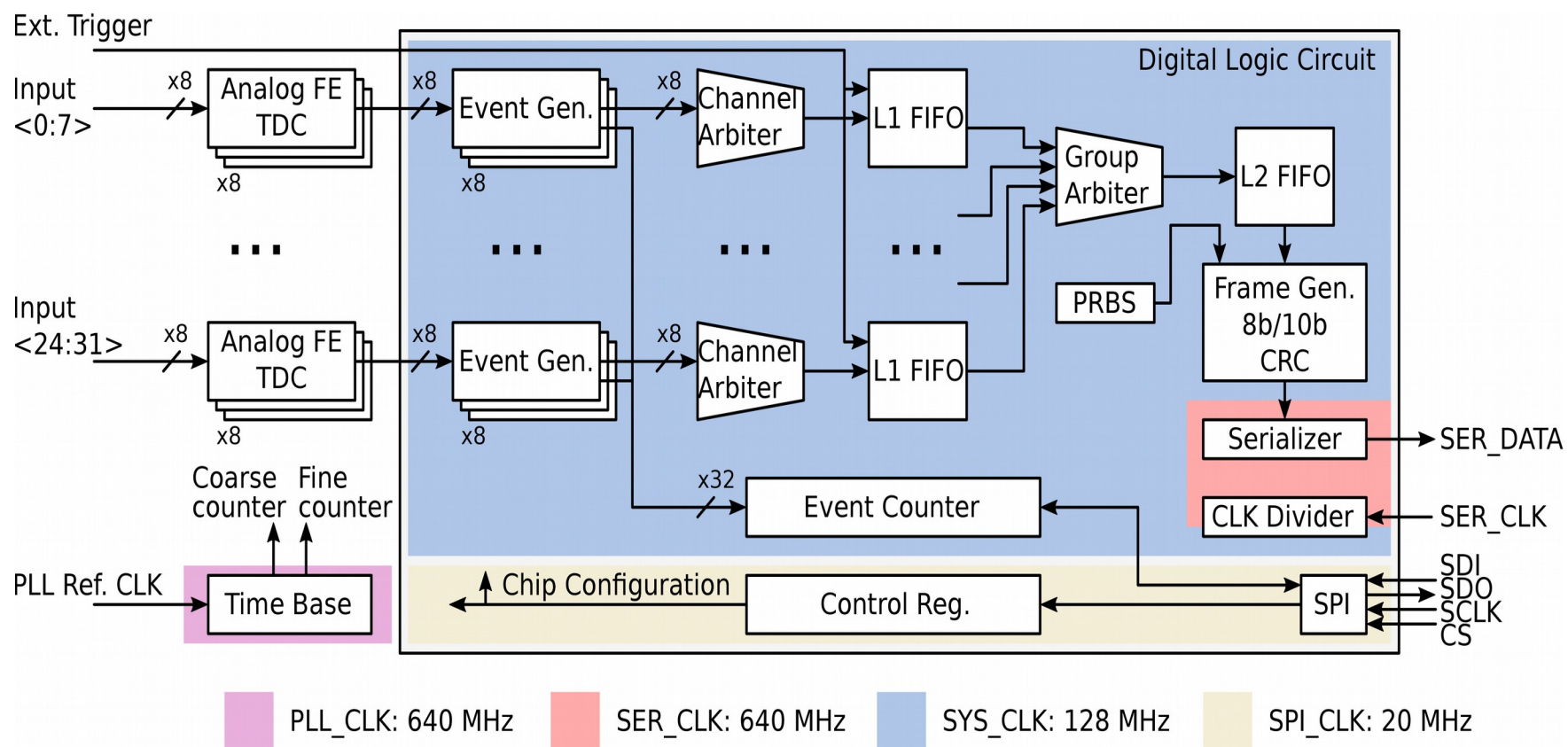

- Gigabit serial data link
- External trigger
- Channel event counter
- CRC for data transmission error detection
- PRBS

MuTRiG: Block Diagram

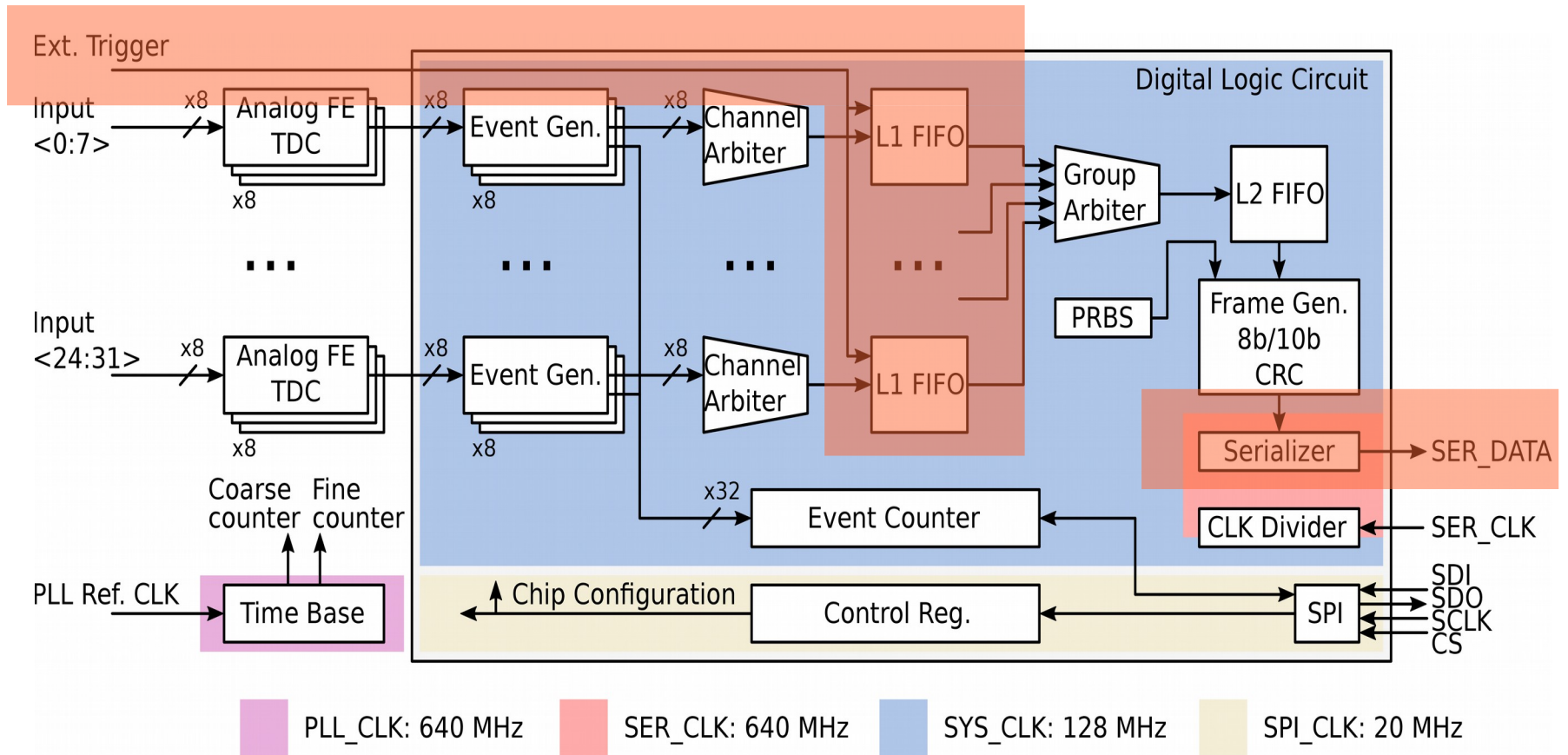

- Gigabit serial data link
- External trigger
- Channel event counter
- CRC for data transmission error detection
- PRBS

MuTRiG: Gigabit Serial Data Link

Double Data Rate Serializer

- Send data bits at both rising and falling edge of serial clock (640MHz): 1.28 Gbps data rate

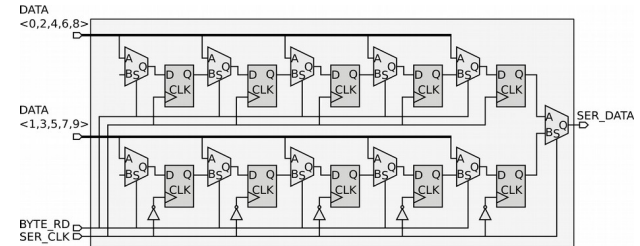

Customized LVDS TX cell

- Driving serial data signal to far end receiver
- An opened eye diagram of PRBS data with 8b/10b encoding at 1.28 Gbps

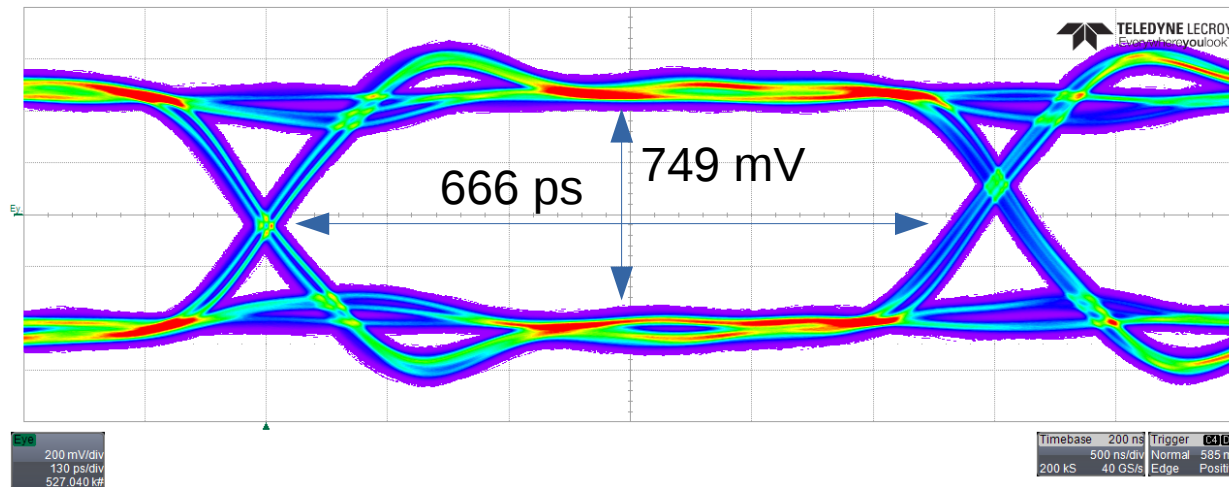
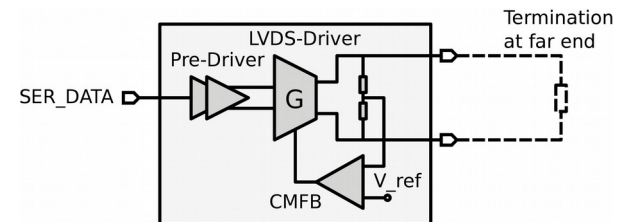

MuTRiG: External Trigger

Send out the events within the match window around the trigger signal

- Configurable match window size
- Tested on KLauS chip.

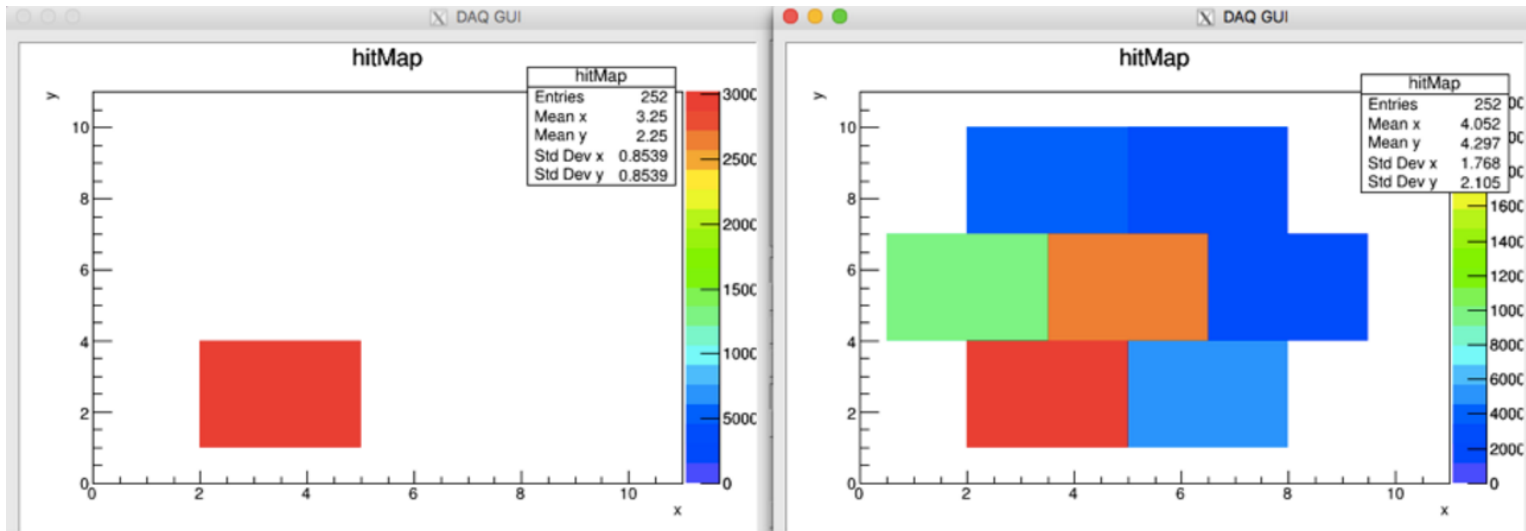
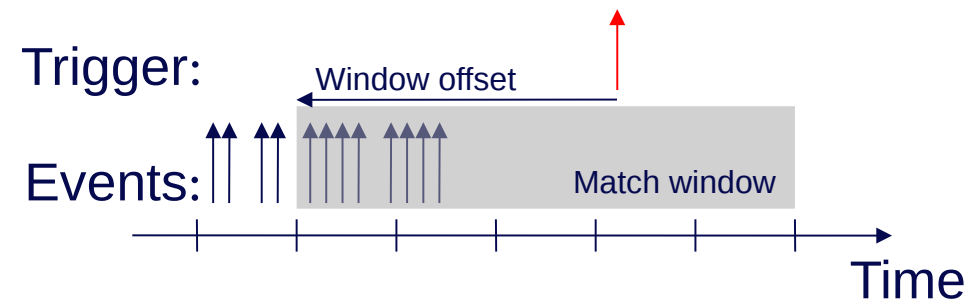

Summary

MuTRiG is

- a 32-channel **mixed-signal** SiPM readout ASIC
- **Fully differential analog front-end + 50 ps timing binning TDC**
 - Analog FE Jitter < 20ps; SPTR = 150 ps FWHM (STiCv3)
- **Gigabit serial data link**
 - Clearly opened eye diagram @ 1.28 Gpbs
- **External trigger** functionality tested on KLauS chip
- Characterization setup is being prepared.

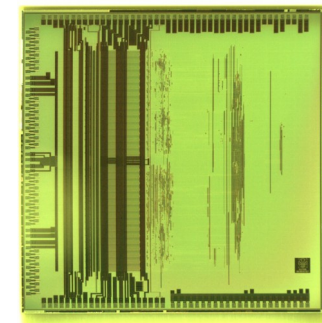
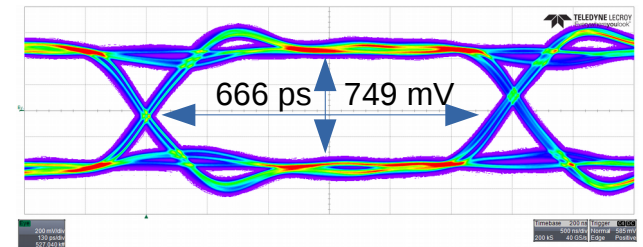
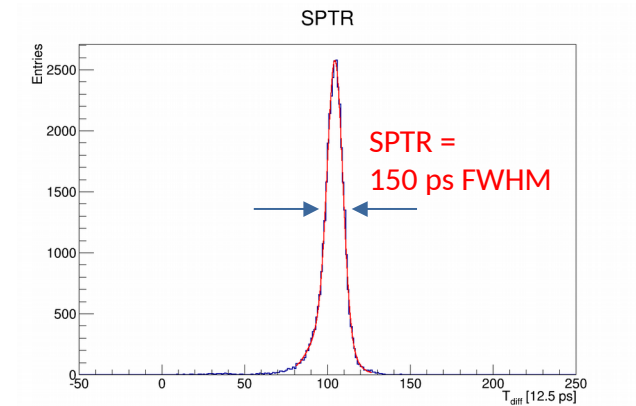

Backup – STiC readout principle

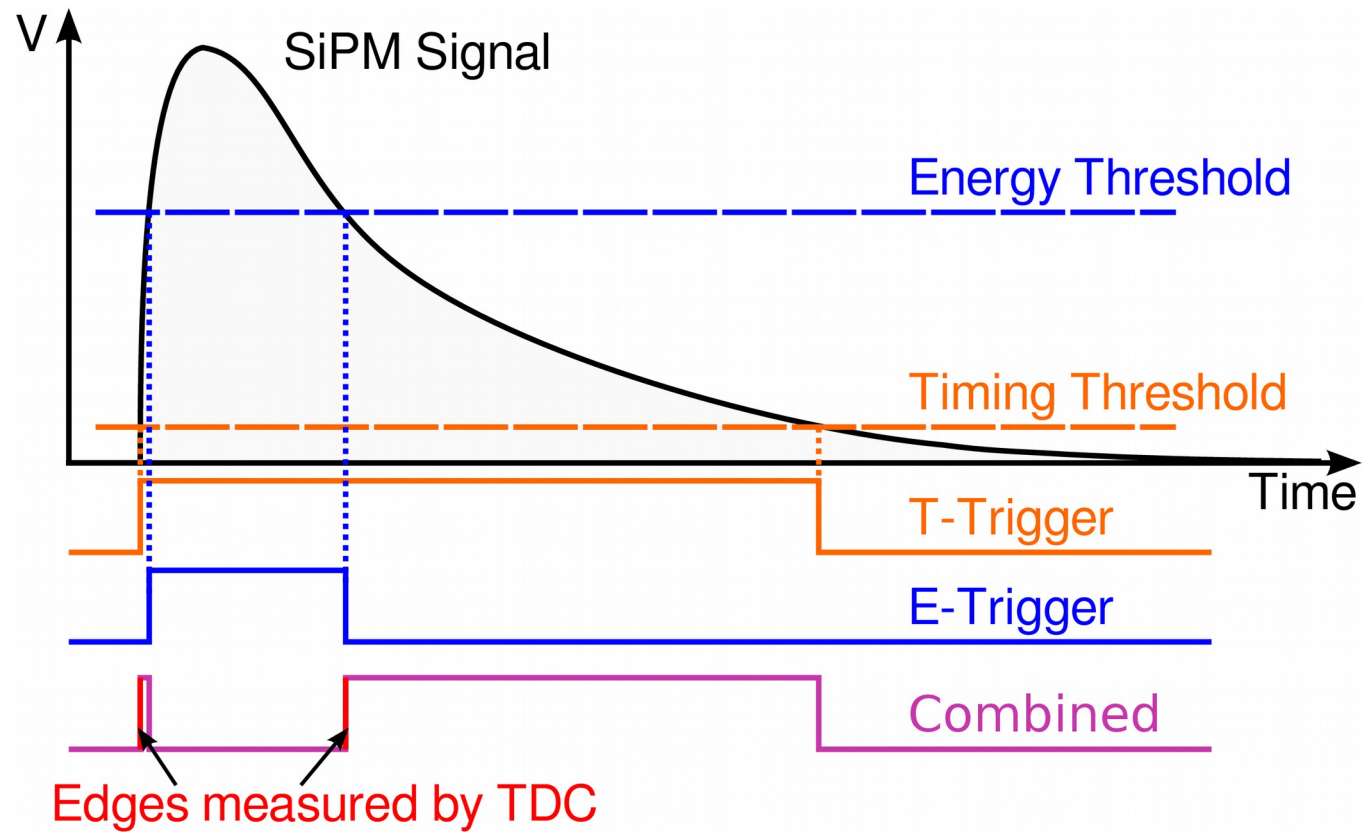

Backup – external trigger

